



# A guide for letter envelope design and clear addressing

How to get it right

26<sup>th</sup> November 2019

# Contents

ENVELOPES .....	4
Letters & cards.....	4
Preferred envelope sizes .....	4
Large Letters .....	5
Preferred Large Letter envelope size.....	5
Machine-readable Large Letters.....	5
LETTER ENVELOPES .....	6
Detailed envelope properties .....	6
EVIDENCE OF PAYMENT (INDICIA) .....	8
Evidence of payment – options.....	8
Printed Postage Impression (PPI): Design information.....	9
PPI printing requirements & general advice for layout of other indicia.....	17
Extra help for you – online PPI Producer: All products (including parcel products).....	20
PPI Designs - All Products (English versions): excluding parcel products.....	21
PPI Designs - All Products (Bilingual Welsh/English version): excluding parcel products.....	23
PPI Designs: Royal Mail 24™ and Royal Mail 48™ only.....	24
3 component English versions.....	24
Royal Mail 24™ .....	24
2 component English versions.....	25
3 component Bilingual Welsh/English version.....	27
2 component Bilingual Welsh/English version .....	28
Franking machine impressions – design information.....	30
Franking impression dimensions .....	30
Franking machine printing requirements .....	31
'Delivered by Royal Mail' mark on franked mail.....	32
Approved Manufacturers, Independents, Inspectors & Maintainers .....	33
ADDRESSING .....	36
Managing Address Data.....	36
Returns Management Service.....	37
The National Change of Address® Update (NCOA® Update) and .....	38
Where to go for more information on address management and data products.....	39
The elements of an address – Inland mail .....	40
Punctuation.....	42
British Forces Post Office (BFPO) Addresses .....	42
ADDRESS STRUCTURE AND LAYOUT .....	43
Address requirements.....	43
Address print requirements.....	45
Address print advice for labels .....	45
Examples showing the layout of information on an address label .....	46
Return Address.....	47
Return Address formatting .....	47
Return Address location .....	48
Window Envelopes.....	49
ADDRESS CLEARZONES & LOCATION.....	49
Delivery Address Block Clear zone .....	50
Delivery Address Block location .....	50
CLEAR ZONES – DESIGN REQUIREMENTS .....	52
Letter format.....	52
Background colours permitted in the 'Tag' and 'Route' code areas .....	54
Large Letter format.....	54
GENERAL ADVICE .....	55
General advice for print quality & finishing.....	55
Where to go for help or more information .....	56

## First impressions

When you send business mail, the envelope is the first point of contact with your customer and it sets the standard for its contents. Your envelope layout will determine how quickly we can deliver your mail.

This guide is designed to help you by providing critical parameters and layout diagrams for the most commonly used DL, C5 and A4 sized paper-based envelopes and provides information relevant to our machine-readable product specifications.

If you have any questions, please don't hesitate to contact us on 08457 950 950 or go to our website for online advice - [Royal Mail - Customer Service](#). We can give you advice on mail piece design, envelope sizes and layouts, paper types and weights, and our range of products and services.

To gain discounts for efficient processing of your mail you must meet the more detailed machine-readable requirements of individual products such as Advertising Mail™, Sustainable® Advertising Mail, Publishing Mail, Subscription Mail, Business Mail 1st Class, Business Mail and Response Services as set out in the product specific terms and user guides. If any details in the specific terms or user guides contradict this guide the specific terms and user guides will apply.

# ENVELOPES

## Envelope dimensions

We recommend the following envelope dimensions as this will allow us to process your mail efficiently through our operational pipeline.

Please note that should any of the maximum dimensions be exceeded it is likely that the format of your item may change and therefore potentially increase the cost of postage.

### Letters & cards

Letter Format	Dimensions permitted
<b>Weight</b>	Maximum 100g
<b>Thickness</b>	Minimum 0.25mm Maximum 5mm
<b>Longer side (length)</b>	recommended minimum 140mm recommended maximum 240mm
<b>Shorter side (depth)</b>	recommended minimum 90mm recommended maximum 165mm

### Preferred envelope sizes

**DL: 110mm x 220mm and C5: 162mm x 229mm**

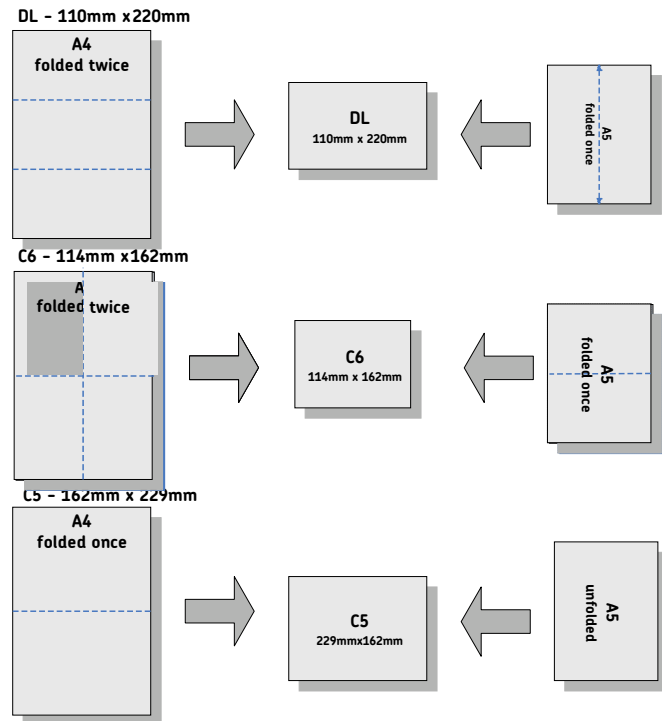

## Large Letters

Large Letter Format	Dimensions permitted
<b>Weight</b>	Maximum 750gms Minimum 10gms
<b>Thickness</b>	Maximum 20mm Minimum 0.5mm
<b>Longer side (length)</b>	Maximum 353mm
<b>Shorter side (depth)</b>	Maximum 250mm

### Preferred Large Letter envelope size

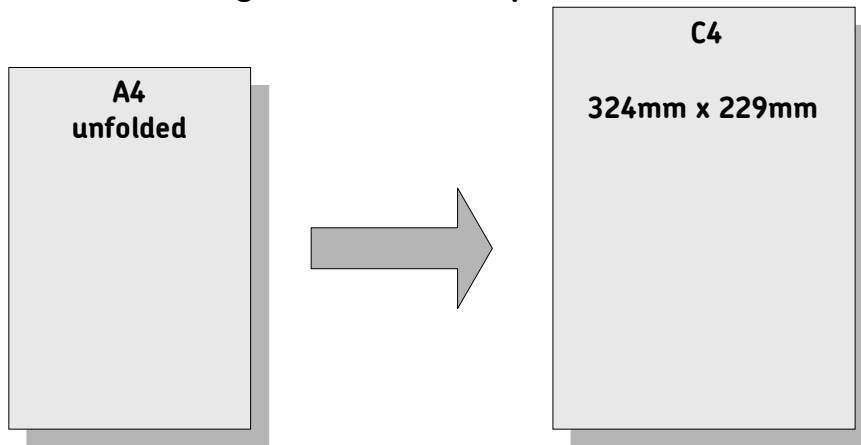

### Machine-readable Large Letters

Please note that these are specific requirements as discounts are given for this product.

Large Letter Format	Dimensions permitted
<b>Weight</b>	Maximum 750gms Minimum 10gms
<b>Thickness</b>	Maximum 10mm Minimum 0.5mm
<b>Longer side (length)</b>	Maximum 345mm Minimum 145mm
<b>Shorter side (depth)</b>	Maximum 245mm Minimum 90mm
<b>Square items</b>	Maximum 245mm x 245mm Minimum 229mm x 229mm

# LETTER ENVELOPES

Please refer to <http://www.royalmailtechnical.com> for details on machine-readable large letter requirements.

## Detailed envelope properties

	Requirements
<b>Material</b>	<ul style="list-style-type: none"> <li>Paper only</li> </ul>
<b>Paper weight (minimum)</b>	<ul style="list-style-type: none"> <li>Envelope paper: 70gsm</li> <li>Single piece mailer: 100gsm</li> <li>Postcards: 200gsm</li> </ul>
<b>Shape</b>	<ul style="list-style-type: none"> <li>Four sides that are straight lines all intersected by a 90° angle</li> <li>i.e. Rectangular, square shapes</li> </ul>
<b>Length</b>	<ul style="list-style-type: none"> <li>Minimum: 140mm</li> <li>Minimum: 145mm (Business Mail - Advanced)</li> <li>Maximum: 240mm</li> </ul>
<b>Height</b>	<ul style="list-style-type: none"> <li>Minimum: 90mm (OCR)</li> <li>Minimum: 102mm (Response Services)</li> <li>Maximum: 165mm</li> </ul>
<b>Orientation</b>	<ul style="list-style-type: none"> <li>Landscape is preferred</li> </ul>
<b>Paper Opacity</b>	<ul style="list-style-type: none"> <li>≥ 85 % (BS ISO 2471 - Paper and board. Determination of opacity (paper backing)</li> </ul>
<b>Paper Absorbency</b>	<ul style="list-style-type: none"> <li>15 - 35 gsm of water in 1 minute (BS EN 20535 - Paper and board. Determination of water absorptiveness.)</li> </ul>
<b>Paper Porosity</b>	<ul style="list-style-type: none"> <li>&lt; 700 ml/minute (BS 6538-2 - Air permeance of paper and board.)</li> </ul>
<b>Paper Colour</b>	<ul style="list-style-type: none"> <li>White, pale and buff coloured envelopes work best through our machines. If your envelope has designs printed on it we ask that you maintain two 'clear zones' free of colour, print, graphics or window material. Please see the section in this guide on 'Clear Zones - Design Requirements'.</li> </ul>
<b>Thickness</b>	<ul style="list-style-type: none"> <li>Minimum: 0.25mm</li> <li>Maximum: 5mm</li> </ul>
<b>Lateral movement of largest insert</b>	<ul style="list-style-type: none"> <li>If the total item (envelope + contents) thickness is up to or equal to 2mm it can be less than or equal to 30mm</li> <li>If the total item (envelope + contents) thickness is up to or equal to 5mm this must be less than or equal to 20mm</li> </ul>
<b>Inserts</b>	<ul style="list-style-type: none"> <li>Large metal objects not permitted e.g. keys, coins</li> <li>Staples maximum size permitted is 24mm by 6mm</li> <li>Paper clips maximum size permitted is 23mm long</li> </ul>

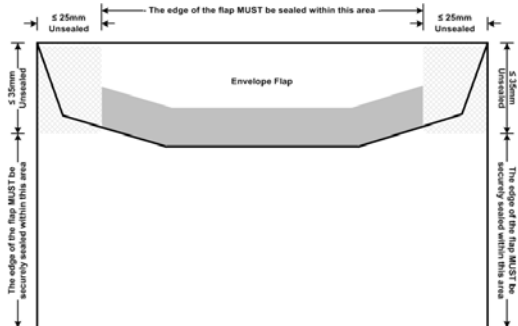
	Requirements
<b>Rigidity / Stiffness</b> <b>Construction</b>	<ul style="list-style-type: none"> <li>• Items must be able to bend into a 'U' shape.</li> <li>• The front of envelope is defined as the side bearing the delivery address and payment indicia</li> <li>• Envelope to be paper-based</li> <li>• Securely sealed on the front, back and all edges</li> <li>• Opening flap may be on the front or the back of the mail item. If the flap folds to the front it must not               <ul style="list-style-type: none"> <li>a) fall within the 'clear zones' – see 'Clear Zones – Design Requirements'</li> </ul> </li> <li>• Envelopes with apertures must have a window film covering the aperture</li> <li>• All window film must be securely and evenly sealed to the inside of the envelope and must be flat when fixed to the envelope</li> <li>• Adhesives used must not leak onto the open envelope surface and must be dry on presentation so that items are not stuck together</li> </ul>
<b>Sealing</b>	<ul style="list-style-type: none"> <li>• Opening flaps to be sealed to within 25mm of the envelope sides and within 35mm from the top of the envelope – as shown below. This applies to all envelope types.</li> </ul> 
<b>Perforations</b>	<ul style="list-style-type: none"> <li>• Roulette perforations are permitted for some products. Please refer to the product specific user guides for details.</li> </ul>
<b>Zip Ties</b>	<ul style="list-style-type: none"> <li>• Zip Tie perforations are permitted for some products. Please refer to the product specific user guides for details</li> </ul>

## **EVIDENCE OF PAYMENT (INDICIA)**

### **Evidence of payment – options**

You have a variety of options to show you have paid the postage on each item of mail. The method you can use depends on the product you are using. For example, you can use stamps, Click & Drop, prepaid stationery, a Printed Postage Impression (PPI) or franking impressions.

For information on all payment options please go to [www.royalmail.com](http://www.royalmail.com) and select 'Discounts and Payment' or click here - [Discounts & Payment](#).

Sending parcels is as easy as 1,2,3. For information on payment for our Royal Mail parcel products, Guaranteed, Tracked and Standard please call 08457 950 950 or speak to your Account Manager.

### **Stamps**

Stamps are the simple way to pay for 1<sup>st</sup> Class, 2<sup>nd</sup> Class and International postage. Stamps are available in books, sheets and rolls from the Royal Mail online shop or from the Post Office™.

Click here for more information on stamps - [www.royalmail.com](http://www.royalmail.com)

### **Click & Drop**

Save time by printing your postage online with this free and easy-to-use service. You don't need new software or equipment – just a computer and printer. All you need to do is log in, select the right service, add address details and then buy, print and send your item. The Price Finder tool helps ensure you select the right postage for your needs. You'll never run out of stamps again!

Click here for more information on Click & Drop - [www.royalmail.com](http://www.royalmail.com)

### **Despatch Manager Online (DMO)**

Our free and easy to use only parcel despatch management system can be used if you use our Royal Mail parcel products including Special Delivery Guaranteed by 9am™, Special Delivery Guaranteed by 1pm™, Royal Mail Tracked 24™, Royal Mail Tracked 48™, Royal Mail 24™ and Royal Mail 48™. This system is designed to help you print barcoded labels and report on your shipping activity.

For more information visit -

[www.royalmail.com/packet-despatch-medium/uk-delivery/royal-mail-despatch-manager-online/](http://www.royalmail.com/packet-despatch-medium/uk-delivery/royal-mail-despatch-manager-online/)



## Prepaid Stationery

With our Pre-paid Stationery, you can send mail easily and conveniently – without a franking machine or stamps. You can also issue Pre-paid Stationery to your customers, to encourage them to contact you or alternatively as a direct mail tool through our customised service.

Click here for more information on Prepaid Stationery - [www.royalmail.com](http://www.royalmail.com)

## Printed Postage Impression (PPI): Design information

When you're sending large quantities of mail, Printed Postage Impressions (PPI) offer a simple, pre-printed alternative to postage stamps or franking machines. Easy to buy and simple to print, PPI could save you time and money.

Before using a Royal Mail PPI you must have a Royal Mail PPI licence number and an active account. Please call 08457 950 950 for details.

Each PPI design, examples below, has its own specification that has to be followed when you produce your artwork. The PPI design must not be altered other than to insert the PPI licence number and, where appropriate, a town name. All other text must remain fixed.

Design information: All Products (excluding parcel products)

Each PPI is made up of two components: the delivery speed indicator and the 'Delivered by Royal Mail' mark. Both must appear on the mailpiece for items being sent to addresses in the UK. For items being sent abroad, you can choose not to include the 'Delivered by Royal Mail' mark within the PPI but you must have the delivery speed indicator.

For all products you have the option of having four sizes of English PPI designs and three sizes of bilingual Welsh/English versions. Full details on PPIs are available at [www.royalmail.com/ppi](http://www.royalmail.com/ppi). Due to space restrictions the smallest bilingual PPI design is text only.

Example of a PPI for all products (excluding parcel products)\* \*\*



\* Please note that 'SOUTHAMPTON 2500' provides an example of where your licence number should appear. Please replace this text with your PPI licence number.

\*\* Please note that the smallest bilingual PPI design has text only for the 'Delivered by Royal Mail' mark as the cruciform could not fit in the specified space.

**Note: For 1<sup>st</sup> and 2<sup>nd</sup> Class Account Mail (Parcels) please continue using existing 1<sup>st</sup> and 2<sup>nd</sup> class PPIs.**

Design information: Parcel products only

If you are sending items using any of our parcel products (including but not limited to Royal Mail 24<sup>TM</sup> or Royal Mail 48<sup>TM</sup>, Royal Mail Tracked 24<sup>TM</sup>, Royal Mail Tracked 48<sup>TM</sup>, Special Delivery Guaranteed by 9am<sup>TM</sup> or Special Delivery Guaranteed by 1pm<sup>TM</sup>), the PPIs are made up of three components: the service graphic box, the 'Delivered by Royal Mail' mark and the delivery speed indicator. The PPI artwork files for all parcel products are available from [www.royalmail.com/ppi](http://www.royalmail.com/ppi).

Generally, we recommend that all three components of a PPI are placed on the same line for items being sent to addresses in the UK. However, if space is limited, a two component PPI comprising of the service graphic box and delivery speed indicator can be used. The 'Delivered by Royal Mail' mark can be moved to another location on the label or parcel but it must appear on the label or parcel.

Example of a 3 component PPI for Royal Mail 24<sup>TM</sup>



PPIs for our other Royal Mail parcel products including, Special Delivery Guaranteed by 9am<sup>TM</sup>, Special Delivery Guaranteed by 1pm<sup>TM</sup>, Royal Mail Tracked 24<sup>TM</sup> and Royal Mail Tracked 48<sup>TM</sup> can be found at [www.royalmail.com/ppi](http://www.royalmail.com/ppi).

**Note: For 1<sup>st</sup> and 2<sup>nd</sup> Class Account Mail (Parcels) please continue using existing 1<sup>st</sup> and 2<sup>nd</sup> class PPIs.**

## Specification – English versions: All products (excluding parcel products)

Note: For 1<sup>st</sup> and 2<sup>nd</sup> Class Account Mail (Parcels) please continue using existing 1<sup>st</sup> and 2<sup>nd</sup> class PPIs.

	<b>DIMENSIONS*</b> (height x width)	<b>DESIGN</b> <b>Postage Paid GB <sup>1</sup></b> <b>Licence Details <sup>2</sup></b>
<b>PPI Design 1</b>	<p>Delivery speed indicator and 'Delivered by Royal Mail': Fixed at 14mmx54mm</p> <p>Delivery speed indicator only: Fixed at 14mmx35mm</p> <p>Distance between Delivery speed indicator and 'Delivered by Royal Mail': 5mm</p>	<p>Helvetica in CAPITAL</p> <p>Recommended font size: 5 point<sup>3</sup></p> <p>Min font size: 4.5 point</p>
<b>PPI Design 2</b>	<p>Delivery speed indicator and 'Delivered by Royal Mail': Fixed at 30mmx58mm</p> <p>Delivery speed indicator only: Fixed at 30mmx30mm</p> <p>Distance between Delivery speed indicator and 'Delivered by Royal Mail': 5mm</p>	<p>Helvetica in CAPITAL</p> <p>Recommended font size: 6.45 point<sup>3</sup></p> <p>Min font size: 6 point</p>
<b>PPI Design 3</b>	<p>Delivery speed indicator and 'Delivered by Royal Mail': Fixed at 22mmx80mm</p> <p>Delivery speed indicator only: Fixed at 22mmx55mm</p> <p>Distance between Delivery speed indicator and 'Delivered by Royal Mail': 5mm</p>	<p>Helvetica in CAPITAL</p> <p>Recommended font size: 6.75 point<sup>3</sup></p> <p>Min font size: 6 point</p>
<b>PPI Design 4</b>	<p>Delivery speed indicator and 'Delivered by Royal Mail': Fixed at 26mmx93mm</p> <p>Delivery speed indicator only: Fixed at 26mmx65mm</p> <p>Distance between Delivery speed indicator and 'Delivered by Royal Mail': 5mm</p>	<p>Helvetica in CAPITAL</p> <p>Recommended font size: 8 point<sup>3</sup></p> <p>Min font size: 7 point</p>

## Specification – Bilingual Welsh/English versions: All products (excluding parcel products)

	<b>DIMENSIONS*</b> (height x width)	<b>DESIGN</b> Postage Paid GB <sup>1</sup> Licence Details <sup>2</sup>
<b>PPI Design 1</b>	Delivery speed indicator and 'Delivered by Royal Mail': Fixed at 14mmx62mm Distance between Delivery speed indicator and 'Delivered by Royal Mail': 5mm	Helvetica in CAPITAL Recommended font size: 5 point <sup>3</sup> Min font size: 4.5 point
<b>PPI Design 2</b>	Delivery speed indicator and 'Delivered by Royal Mail': Fixed at 22mmx80mm Distance between Delivery speed indicator and 'Delivered by Royal Mail': 5mm	Helvetica in CAPITAL Recommended font size: 6.5 point <sup>3</sup> Min font size: 6 point
<b>PPI Design 3</b>	Delivery speed indicator and 'Delivered by Royal Mail': Fixed at 26mmx93mm Distance between Delivery speed indicator and 'Delivered by Royal Mail': 5mm	Helvetica in CAPITAL Recommended font size: 8 point <sup>3</sup> Min font size: 7 point

\* These PPI specifications do not apply to items sent using our parcel products including but not limited to Royal Mail 24™, Royal Mail 48™, Royal Mail Tracked 24™, Royal Mail Tracked 48™, Special Delivery Guaranteed By 9am™ and Special Delivery Guaranteed By 1pm™ which are set out below. For labels where space is limited, the two components can be separated but both must appear on the packaging or label. For items being sent abroad, you have the option to only use the delivery speed indicator. Images of the above PPI designs are shown from page 26 onwards.

## Specification – 3 component English versions: All Parcel products only

Note: For 1<sup>st</sup> and 2<sup>nd</sup> Class Account Mail (Parcels) please continue using existing 1<sup>st</sup> and 2<sup>nd</sup> class PPIs.

	<b>DIMENSIONS*</b> (height x width)	<b>DESIGN</b> Postage Paid GB <sup>1</sup> Licence Details <sup>2</sup>
<b>PPI Design 1</b>	Service graphic box, delivery speed indicator and 'Delivered by Royal Mail': Fixed at 14mmx79.5mm Delivery speed indicator only: Fixed at 14mmx35mm Distance between delivery speed indicator and 'Delivered by Royal Mail': 5mm Distance between 'Delivered by Royal Mail' mark and service graphic box: 5mm	Helvetica in CAPITAL Recommended font size: 5 point <sup>3</sup> Min font size: 4.5 point
<b>PPI Design 2</b>	Service graphic box, delivery speed indicator and 'Delivered by Royal Mail': Fixed at 30mmx106.5mm Delivery speed indicator only: Fixed at 30mmx30mm Distance between delivery speed indicator and 'Delivered by Royal Mail': 5mm Distance between 'Delivered by Royal Mail' mark and service graphic box: 5mm	Helvetica in CAPITAL Recommended font size: 6.45 point <sup>3</sup> Min font size: 6 point
<b>PPI Design 3</b>	Service graphic box, delivery speed indicator and 'Delivered by Royal Mail': Fixed at 22mmx117mm Delivery speed indicator only: Fixed at 22mmx55mm Distance between delivery speed indicator and 'Delivered by Royal Mail': 5mm Distance between 'Delivered by Royal Mail' and service graphic box: 5mm	Helvetica in CAPITAL Recommended font size: 6.75 point <sup>3</sup> Min font size: 6 point
<b>PPI Design 4</b>	Service graphic box, delivery speed indicator and 'Delivered by Royal Mail': Fixed at 26mmx136mm Delivery speed indicator only: Fixed at 26mmx65mm Distance between Delivery speed indicator and 'Delivered by Royal Mail': 5mm Distance between 'Delivered by Royal Mail' mark and service graphic box: 5mm	Helvetica in CAPITAL Recommended font size: 8 point <sup>3</sup> Min font size: 7 point

**Specification – 2 component English versions: Parcel products only  
(where space is limited)**

	<b>DIMENSIONS*</b> (height x width)	<b>DESIGN</b> <b>Postage Paid GB <sup>1</sup></b> <b>Licence Details <sup>2</sup></b>
<b>PPI Design 1</b>	Service graphic box and delivery speed indicator: Fixed at 14mmx60.5mm Delivery speed indicator only: Fixed at 14mmx35mm Distance between Delivery speed indicator and service graphic box: 5mm	Helvetica in CAPITAL Recommended font size: 5 point <sup>3</sup> Min font size: 4.5 point
<b>PPI Design 2</b>	Service graphic box and delivery speed indicator: Fixed at 30mmx79mm Delivery speed indicator only: Fixed at 30mmx30mm Distance between delivery speed indicator and service graphic box: 5mm	Helvetica in CAPITAL Recommended font size: 6.45 point <sup>3</sup> Min font size: 6 point
<b>PPI Design 3</b>	Service graphic box and delivery speed indicator: Fixed at 22mmx92.5mm Delivery speed indicator only: Fixed at 22mmx55mm Distance between delivery speed indicator and service graphic box: 5mm	Helvetica in CAPITAL Recommended font size: 6.75 point <sup>3</sup> Min font size: 6 point
<b>PPI Design 4</b>	Service graphic box and delivery speed indicator: Fixed at 26mmx108.5mm Delivery speed indicator only: Fixed at 26mmx65mm Distance between Delivery speed indicator and service graphic box: 5mm	Helvetica in CAPITAL Recommended font size: 8 point <sup>3</sup> Min font size: 7 point

Note: For labels where space is limited, the 2 component PPI can be used but the 'Delivered by Royal Mail' mark must be present on the label/ parcel. For items being sent abroad, you have the option to only use the delivery speed indicator. Images of the above PPI designs are shown from page 26 onwards.

## Specification – 3 component Bilingual Welsh/English versions: Parcel products only

	<b>DIMENSIONS*</b> (height x width)	<b>DESIGN</b> Postage Paid GB <sup>1</sup> Licence Details <sup>2</sup>
<b>PPI Design 1</b>	<p>Service graphic box, delivery speed indicator and 'Delivered by Royal Mail': Fixed at 14mmx88mm</p> <p>Distance between delivery speed indicator and 'Delivered by Royal Mail': 5mm</p> <p>Distance between 'Delivered by Royal Mail' and service graphic box: 5mm</p>	<p>Helvetica in CAPITAL</p> <p>Recommended font size: 5 point<sup>3</sup></p> <p>Min font size: 4.5 point</p>
<b>PPI Design 2</b>	<p>Service graphic box, delivery speed indicator and 'Delivered by Royal Mail': Fixed at 22mmx114.5mm</p> <p>Distance between Delivery speed indicator and 'Delivered by Royal Mail': 5mm</p> <p>Distance between 'Delivered by Royal Mail' mark and service graphic box: 5mm</p>	<p>Helvetica in CAPITAL</p> <p>Recommended font size: 6.5 point<sup>3</sup></p> <p>Min font size: 6 point</p>
<b>PPI Design 3</b>	<p>Service graphic box, delivery speed indicator and 'Delivered by Royal Mail': Fixed at 26mmx134mm</p> <p>Distance between delivery speed indicator and 'Delivered by Royal Mail': 5mm</p> <p>Distance between 'Delivered by Royal Mail' mark and service graphic box: 5mm</p>	<p>Helvetica in CAPITAL</p> <p>Recommended font size: 8 point<sup>3</sup></p> <p>Min font size: 7 point</p>

## Specification – 2 component Bilingual Welsh/English versions: Parcel products only

	<b>DIMENSIONS*</b> (height x width)	<b>DESIGN</b> <b>Postage Paid GB</b> <sup>1</sup> <b>Licence Details</b> <sup>2</sup>
<b>PPI Design 1</b>	Service graphic box and delivery speed indicator: Fixed at 14mmx60.5mm Distance between Delivery speed indicator and service graphic box: 5mm	Helvetica in CAPITAL Recommended font size: 5 point <sup>3</sup> Min font size: 4.5 point
<b>PPI Design 2</b>	Service graphic box and delivery speed indicator: Fixed at 22mmx92.5mm Distance between Delivery speed indicator and service graphic box: 5mm	Helvetica in CAPITAL Recommended font size: 6.5 point <sup>3</sup> Min font size: 6 point
<b>PPI Design 3</b>	Service graphic box and delivery speed indicator: Fixed at 26mmx108.5mm Distance between Delivery speed indicator and service graphic box: 5mm	Helvetica in CAPITAL Recommended font size: 8 point <sup>3</sup> Min font size: 7 point

Note: For labels where space is limited, the 2 component PPI can be used but the 'Delivered by Royal Mail' mark must be present on the label / parcel. For items being sent abroad, you have the option to only use the delivery speed indicator. Images of the above PPI designs are shown from page 25 onwards.

These PPI specifications apply only to items sent using our parcel products, including but not limited to Royal Mail 24™, Royal Mail 48™, Royal Mail Tracked 24™, Royal Mail Tracked 48™, Special Delivery Guaranteed By 9am™ and Special Delivery Guaranteed By 1pm™.

### **<sup>1</sup> Postage Paid GB**

The words "Postage Paid" and the initials "GB" must appear in all designs irrespective of which PPI you are using and the destination of your mail.

### **<sup>2</sup> Licence details**

The PPI licence number must appear below the words "Postage Paid" and the initials "GB". The PPI licence number must always appear after HQ if you are using a national PPI licence e.g. HQ 2500, or after the town name if you have a local PPI licence e.g. SOUTHAMPTON 2500.

### **<sup>3</sup> Font size**

If you have a local PPI licence, the town name and PPI licence number must fit on one line. If the town name is long there is a chance the text will spill outside the design boundary. If this happens, please reduce the font size of the town name and licence number to a legible size. If you still have difficulties, please call our Royal Mail Sales Centre on 08457 950 950 and they will advise you of an appropriate abbreviation.



## PPI printing requirements & general advice for layout of other indicia

	Requirements
<b>CLEAR ZONE</b>	<ul style="list-style-type: none"> <li>There must be a clear zone of 2mm around the PPI. This is also applicable when dark substrates (envelopes) have been used. This 2mm clear zone can fall below the 40mm Indicia area.</li> </ul>
<b>COLOUR</b>	<ul style="list-style-type: none"> <li>All designs should be in black and white with the PPI printed in black on a white background.</li> <li>With prior agreement, the PPI can be printed as a dark indicia on a light background.</li> <li>If you are using dark coloured envelopes you should leave a white or light panel on the envelope where the PPI is to be printed. This panel should extend at least 1mm all around the PPI you use.</li> <li>It is important that the PPIs are clear and readable by our postal staff and automated sorting machines. If you do change the colours of the PPI then contact our Royal Mail Sales Centre on 08457 950 950 before committing the designs to print.</li> </ul>
<b>CONTRAST</b>	<ul style="list-style-type: none"> <li>The indicia contrast (Contrast Ratio) on similar kinds of backgrounds must be more than or equal to 20% (and 40% if on inconsistent backgrounds), the indicia being darker than the background.</li> <li>It is important that the PPIs are clear and readable by our postal staff and automated sorting machines. If you do change the colours of the PPI or you are not sure about the contrast between it and your background envelope then contact our Royal Mail Sales Centre on 08457 950 950 before committing the designs to print.</li> </ul>
<b>DESIGN</b>	<ul style="list-style-type: none"> <li>The PPI design must not be printed as a negative. e.g. white on black.</li> </ul>
<b>POLYWRAPPED ITEMS</b>	<ul style="list-style-type: none"> <li>Ideally the white areas should be pre-printed white.</li> <li>If this isn't possible, leave them transparent but again ensure that the printed areas are darker than the background envelope and that there is a good contrast to it.</li> </ul>
<b>POSITION – Poly and 3D items (applies to all indicia)</b>	<ul style="list-style-type: none"> <li>Please follow the design requirements as for letters               <ul style="list-style-type: none"> <li>Location</li> <li>PPI Design options</li> </ul> </li> </ul>
<b>PRINT RESOLUTION</b>	<ul style="list-style-type: none"> <li>The indicia must be printed at a minimum resolution of 300dpi.</li> </ul>
<b>SKEW (applies to all indicia)</b>	<ul style="list-style-type: none"> <li>The maximum skew for the whole indicia is +/- 20° from the horizontal edge.</li> </ul>

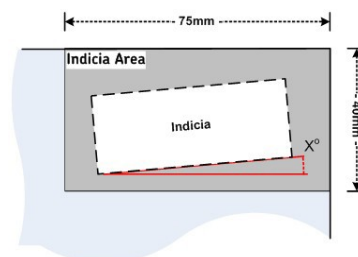

## Requirements

### POSITION – Letters and Large Letters (applies to all indicia excluding indicia for parcel products)

- For letters, the indicia (which must include the 'Delivered by Royal Mail' mark) must be located in the top right hand corner of the envelope, above and to the right of the delivery address.
- The PPI should be positioned 5mm from the top of the envelope and 5mm from the right hand edge of the envelope.
- The area of the envelope recognised as the Indicia area is positioned above and to the right of the Delivery Address Block, and consists of two parts:
  1. Indicia Area: this extends 40mm from the top of the envelope and 75mm from the right hand edge of the envelope.
  2. Additional Indicia Area: this extends the Indicia Area length by 28mm when customers choose to use the larger English PPI designs 3 and 4 or Bilingual PPI designs 2 and 3. The overall area becomes 40mm high and 103mm long.

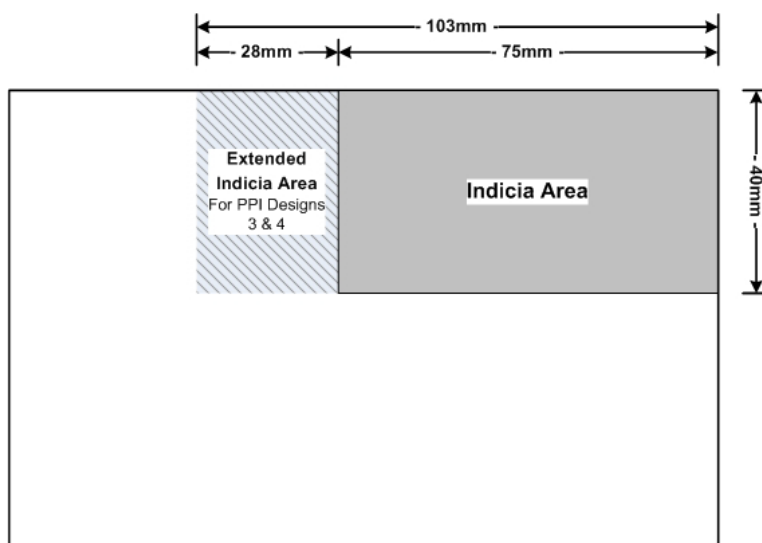

### POSITION – For parcel products only

**Note: For 1<sup>st</sup> and 2<sup>nd</sup> Class Account Mail (Parcels) please continue using existing 1<sup>st</sup> and 2<sup>nd</sup> class PPIs.**

- Generally please follow the design requirements as for letters.
- For large letter format, we recommend that the English 3 component PPI design 1 is used, or 2 component PPI design 1, 2 or 3 is used so that they fit within the extended indicia area defined above.
  - Some of the PPI options for parcel products including Special Delivery Guaranteed by 9m™, Special Delivery Guaranteed by 9am™, Royal Mail Tracked 24™, Royal Mail Tracked 48™, Royal Mail 24™ and Royal Mail 48™ extend beyond the length of the extended indicia area as defined above for letters. Apart from the designs recommended for large letter format, please use any of the various design options for parcel products named above which are also suitable for your parcels.
  - The PPI should be positioned 5mm from the top of the envelope and 5mm from the right hand edge of the envelope.
  - The indicia must be located in the top right hand corner of the envelope, above and to the right of the delivery address.
  - The area of the envelope recognised as the indicia area is positioned above and to the right of the Delivery Address Block.

## Mail pieces that use labels for the address and PPI: All products (excluding parcel products)

Generally, you should follow the printing requirements and general advice as defined above for Letters and Large Letters. If space is limited, you may separate the two components of the PPI (delivery speed indicator and 'Delivered by Royal Mail' mark) but both components must appear on the packaging or label to addresses in the UK. Below is a recommended secondary layout.



## Mailpieces that use labels for the address and PPI: Parcel products only

If you use Royal Mail 24™, Royal Mail 48™, Royal Mail Tracked 24™, Royal Mail Tracked 48™, Special Delivery Guaranteed by 9am™ or Special Delivery Guaranteed by 1pm™, the PPI should contain 3 components **the service graphic box, the 'Delivered by Royal Mail' mark and the delivery speed indicator.**

Generally, we recommend that all 3 components are placed on the same line for items being sent to addresses in the UK. But if space is limited, the 2 component PPI can be used. The 'Delivered by Royal Mail' mark can be moved to another location on the label but it must appear on the label or parcel. Below is a recommended layout for a 2 component PPI.



In general the same printing requirements and general advice as defined above for letters and large letters apply for parcel products. The PPIs for these products now contain 3 components: the service graphic box, the 'Delivered by Royal Mail' mark and the delivery speed indicator.

NB For further details on parcel products and items that use barcodes including Royal Mail Tracked 24™ and Royal Mail Tracked 48™ and Royal Mail Special Delivery Guaranteed by 9am™ and Royal Mail Special Delivery Guaranteed by 1pm™, please refer to the Customers Solutions guides at [www.royalmail.com/coss](http://www.royalmail.com/coss) or speak to your account Manager.

## Extra help for you – online PPI Producer: All products (including parcel products)

You can use our [online PPI producer](#) to create ready-to-print PPIs. The PPI Producer has five easy steps to create the PPI.

Note: The PPI producer does not produce PPIs for the following parcel products; Royal Mail Tracked 24™, Royal Mail Tracked 48™, Special Delivery Guaranteed by 9am™ and Special Delivery Guaranteed by 1pm™. These can however be downloaded as artwork files from [www.royalmail.com/ppi](http://www.royalmail.com/ppi).

1. Enter your PPI licence number
2. Choose between 1st Class, 2nd Class, Economy or Royal Mail 24™, Royal Mail 24 Signed For™, Royal Mail 48™, Royal Mail 48 Signed For™ speed indicator
3. Choose the PPI design that works best for your mail. Note that for Business Mail – Advanced, you must use either English PPI designs 1 or 2. For the bilingual Welsh/English version you must use the smaller bilingual PPI design 1.
4. Preview what you have selected
5. Choose the file format that best suits you – JPG (compression of photographic image) or TIFF (bitmap graphics file format).
6. While pressing ‘download’ you must keep the CTRL key pressed down

Alternatively you can download the raw files of the PPI designs from [www.royalmail.com/ppi](http://www.royalmail.com/ppi). We recommend that you use a professional designer or printer to insert your licence details to ensure that these guidelines are followed correctly. As long as you download the artwork and reproduce it exactly as the specification states, there is no need for your artwork to be checked by us before you post.

All Royal Mail PPIs are the copyright, trademarks and designs of Royal Mail Group 2012. All rights reserved. By downloading the Royal Mail PPIs you acknowledge that you have read, accept and are bound by our [Terms and Conditions](#) for Royal Mail PPI use. If you do not accept all of the terms please do not proceed to download the PPIs.

# PPI Designs - All Products (English versions): excluding parcel products

Note: For 1<sup>st</sup> and 2<sup>nd</sup> Class Account Mail (Parcels) please continue to use existing 1<sup>st</sup> and 2<sup>nd</sup> class PPIs.

## 1<sup>st</sup> Class

PPI Design 1: 14mmx54mm



PPI Design 3: 22mmx80mm



PPI Design 2: 30mmx58mm



PPI Design 4: 26mmx93mm



## 2<sup>nd</sup> Class

PPI Design 1: 14mmx54mm



PPI Design 3: 22mmx80mm



PPI Design 2: 30mmx58mm



PPI Design 4: 26mmx93mm



## Economy

PPI Design 1: 14mmx54mm



PPI Design 3: 22mmx80mm



PPI Design 2: 30mmx58mm



PPI Design 4: 26mmx93mm



# PPI Designs - All Products (Bilingual Welsh/English version): excluding parcel products

## 1<sup>st</sup> Class

PPI Design 1: 14mmx62mm

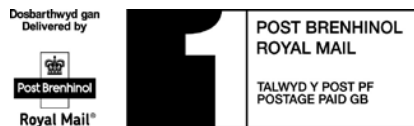

PPI Design 3: 26mmx93mm

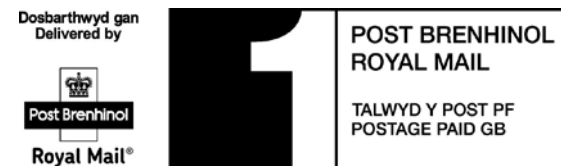

PPI Design 2: 22mmx80mm

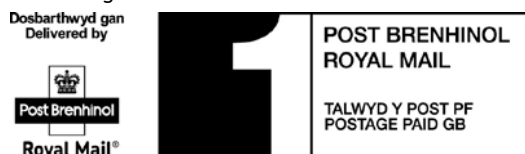

## 2<sup>nd</sup> Class

PPI Design 1: 14mmx62mm



PPI Design 3: 26mmx93mm



PPI Design 2: 22mmx80mm

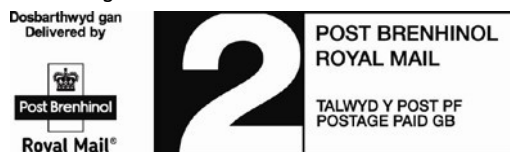

## Economy

PPI Design 1: 14mmx62mm



PPI Design 3: 26mmx93mm



PPI Design 2: 22mmx80mm



\* Please refer to product user guides for full print requirements

Please note: not to scale

# PPI Designs: Royal Mail 24™ and Royal Mail 48™ only

## 3 component English versions

Note: For 1<sup>st</sup> and 2<sup>nd</sup> Class Account Mail (Parcels) please continue using existing 1<sup>st</sup> and 2<sup>nd</sup> class PPIs.

### Royal Mail 24™

PPI Design 1: 14mmx79.5mm



PPI Design 3: 22mmx117mm



PPI Design 2: 30mmx106.5mm

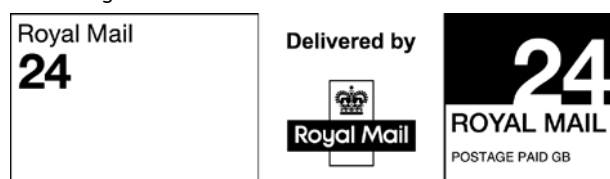

PPI Design 4: 26mmx136mm



### Royal Mail 24 Signed For™

PPI Design 1: 14mmx79.5mm



PPI Design 3: 22mmx117mm



PPI Design 2: 30mmx106.5mm



PPI Design 4: 26mmx136mm



### Royal Mail 48™

PPI Design 1: 14mmx79.5mm



PPI Design 3: 22mmx117mm



PPI Design 2: 30mmx106.5mm

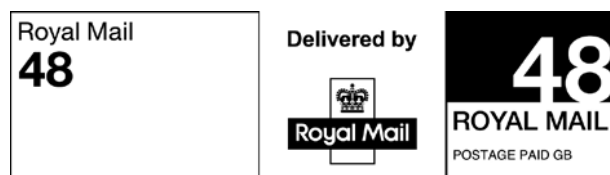

PPI Design 4: 26mmx136mm



Please note: not to scale

## Royal Mail 48 Signed For™

PPI Design 1: 14mmx79.5mm



PPI Design 3: 22mmx117mm



PPI Design 2: 30mmx106.5mm

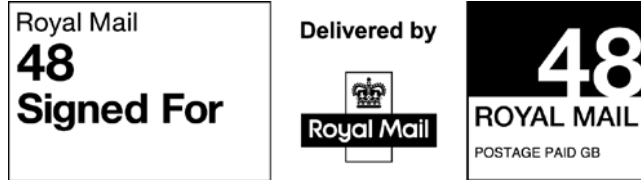

PPI Design 4: 26mmx136mm



## 2 component English versions

### Royal Mail 24™

PPI Design 1: 14mmx60.5mm



PPI Design 3: 22mmx92.5mm



PPI Design 2: 30mmx79mm



PPI Design 4: 26mmx108.5mm



### Royal Mail 24 Signed For™

PPI Design 1: 14mmx60.5mm



PPI Design 3: 22mmx92.5mm



PPI Design 2: 30mmx79mm



PPI Design 4: 26mmx108.5mm





## Royal Mail 48™

PPI Design 1: 14mmx60.5mm



PPI Design 3: 22mmx92.5mm



PPI Design 2: 30mmx79mm



PPI Design 4: 26mmx108.5mm



## Royal Mail 48 Signed For™

PPI Design 1: 14mmx60.5mm



PPI Design 3: 22mmx92.5mm



PPI Design 2: 30mmx79mm



PPI Design 4: 26mmx108.5mm



For PPIs for all other parcel products including Special Delivery Guaranteed by 9am™, Special Delivery Guaranteed by 1pm™, Royal Mail Tracked 24™ and Royal Mail Tracked 48™ visit [www.royalmail.com/ppi](http://www.royalmail.com/ppi).

Please note: not to scale.

### 3 component Bilingual Welsh/English version

#### Royal Mail 24™

PPI Design 1: 14mmx88mm

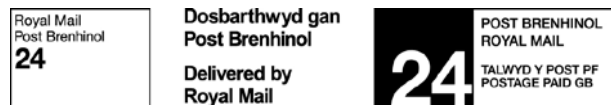

PPI Design 3: 26mmx134mm



PPI Design 2: 22mmx114.5mm



#### Royal Mail 24 Signed For™

PPI Design 1: 14mmx88mm

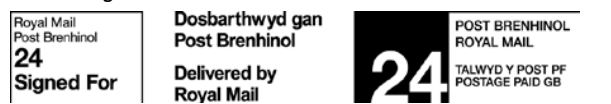

PPI Design 3: 26mmx134mm



PPI Design 2: 22mmx114.5mm



#### Royal Mail 48™

PPI Design 1: 14mmx88mm

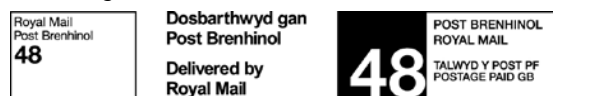

PPI Design 3: 26mmx134mm



PPI Design 2: 22mmx114.5mm



Please note: not to scale

## Royal Mail 48 Signed For™

PPI Design 1: 14mmx88mm

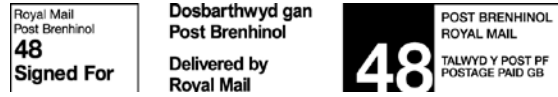

PPI Design 3: 26mmx134mm



PPI Design 2: 22mmx114.5mm



## 2 component Bilingual Welsh/English version

### Royal Mail 24™

PPI Design 1: 14mmx60.5mm



PPI Design 3: 26mmx108.5mm



PPI Design 2: 22mmx92.5mm



### Royal Mail 24 Signed For™

PPI Design 1: 14mmx60.5mm



PPI Design 3: 26mmx108.5mm



PPI Design 2: 22mmx92.5mm



Please note: not to scale

## Royal Mail 48™

PPI Design 1: 14mmx60.5mm



PPI Design 3: 26mmx108.5mm



PPI Design 2: 22mmx92.5mm



## Royal Mail 48 Signed For™

PPI Design 1: 14mmx60.5mm



PPI Design 3: 26mmx108.5mm



PPI Design 2: 22mmx92.5mm



Please note: not to scale

## Franking machine impressions - design information

Franking machines can print both franking impressions and PPIs. A franking impression is a payment channel mark used by business customers who pre-pay for their mail using franking machines. Franking impressions are permitted for most unsorted letter products but are not permitted for any of the sorted product options.

The Franked mail indicia that can be produced by a Franking machine is made up of the following components:

- Town Circle (Roundel): This provides the date the item was posted and the geographic location that it was posted from. The Town Circle may be preceded by a customer defined advertising slogan, return address, or reference information. This must state the post town (e.g. York) or the postcode and it is no longer necessary to state the county (e.g. Kent).
- Crown Box (Data Block): This provides the postage value that has been paid and Franking machine id number



## Franking impression dimensions

### Town Circle (Roundel)

- The diameter of the outer circle must be 24mm (+3mm -1mm).
- There must be a 4mm gap between the inner and outer circle.
- Details of the post town and county in which the mail is posted must be printed in capital letters between the circles; the post town being printed at the top and the county at the bottom. Note that it is no longer necessary to include the county.
- Each date character must be 2mm high and 1mm wide.

### Crown Box (Data Block)

- This must be 26mm (+4mm -2mm) wide and 22mm (+5mm) high.
- The central element of the block is a rectangular outline. To the left of the rectangle, the words 'GREAT BRITAIN' must be printed in capital letters and reading from bottom to top. To the right of the rectangle, the words 'POSTAGE PAID' must be printed in capital letters and reading from top to bottom.
- The crown must be printed in the central zone of the rectangle. This must be 8mm wide and 6mm high.
- The postage value must be printed towards the centre of the rectangle. The characters must be 5mm high and 2mm wide.
- The 'Franking machine number' must be printed in the bottom third of the rectangle. The characters must be 2.5mm high and 1.5mm wide
- The 'Franking machine number' must consist of up to 10 characters and conform to one of the following formats:

NAANNNNNN ANNNNNNNN AANNNNNNNN	AANNNNNNN AANNNNNAN	AAANNNNNNN AAANNNNNN
--------------------------------------	------------------------	-------------------------

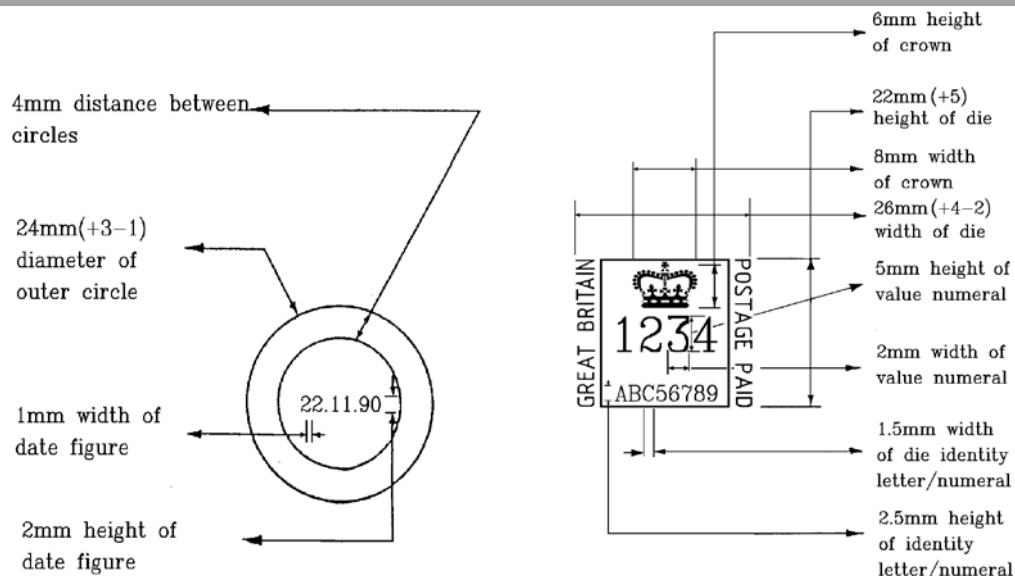

## Franking machine printing requirements

	Requirements
<b>Position / Clear Zone</b>	<ul style="list-style-type: none"> <li>A clear zone of 2mm is required around the indicia.</li> <li>A minimum gap of 5mm (-0,+1mm) gap is required on either side of the town circle (roundel)</li> </ul>
<b>Indicia Colour</b>	<ul style="list-style-type: none"> <li>The indicia must be printed using either red for non-Smart franking machines or blue for Smart franking (Customers can transition to blue ink as their red ink runs out) Business Mail – Smart franking customers only, blue ink</li> </ul>
<b>Red ink pantone</b>	<ul style="list-style-type: none"> <li>The red ink used must be Pantone 185U.</li> </ul>
<b>Blue ink pantone</b>	<ul style="list-style-type: none"> <li>The pantone for the blue ink will be specified at a later date.</li> </ul>
<b>Print Quality (IJP)</b>	<ul style="list-style-type: none"> <li>The indicia must be printed at a minimum resolution of 200dpi.</li> </ul>
<b>Contrast Ratio</b>	<ul style="list-style-type: none"> <li>The indicia contrast on homogeneous backgrounds must be <math>\geq 20\%</math>, and <math>\geq 40\%</math> for inhomogeneous backgrounds, the indicia being darker than the background.</li> </ul>
<b>Skew</b>	<ul style="list-style-type: none"> <li>The maximum skew for the indicia and the value is <math>\pm 10^\circ</math> from the horizontal axis.</li> </ul>
<b>Return Addressing standards</b>	<ul style="list-style-type: none"> <li>Please always use the key words 'Return Address' as the header for any return address information.</li> </ul>

## 'Delivered by Royal Mail' mark on franked mail

We will print the 'Delivered by Royal Mail' mark on franked, machine-readable letter items using our automation equipment in our Mail Centres.

For landscape mail, this mark will be printed in the top left corner in an area 37mm long and 35mm high whilst on portrait C5 mail the mark is printed in a 35mm by 35mm area on the right side and 135mm up from the corner. (These measurements allow for a 5mm clear area around the mark). The printed mark is in addition to the two Royal Mail Codemarks already applied on the right hand side of the Letter.



For portrait mail, this mark will be printed beneath the payment indicia in a 25mm area which starts 140mm from the top right of the leading edge of the envelope, see the images below. This is because the mailpiece will be processed on its longest edge with the franking impression in the top left corner.

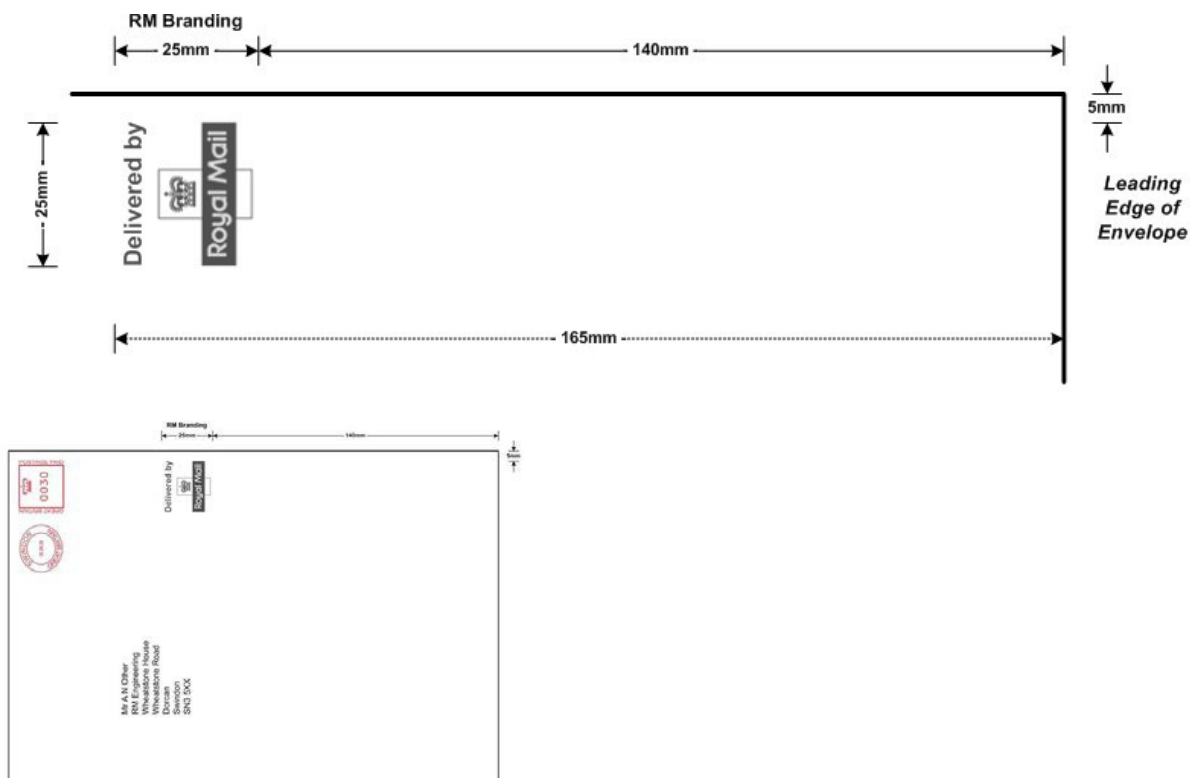

We would recommend that if you choose to have logos, slogans or creative artwork on the face of your item, you avoid the area of the envelope, as shown in the images above.

## Approved Manufacturers, Independents, Inspectors & Maintainers

For an up to date list, links to the companies' listed and further details please visit [Royal Mail Ltd](#) and select 'Discounts & Payment' then 'Franking'. Alternatively, please [click here](#) - [Royal Mail Franking](#)

Company	Address	Contact details	Services
<b>Ashcroft Mailing Solutions</b>	Kinwarton House Captains Hill Alcester Warwickshire B49 6HA	TEL: 0845 293 0465 FAX: 0845 293 0466	Supplier Inspector Maintainer
<b>Digital Communication Systems Limited</b>	7-8 Benton Terrace Sandyford Road Jesmond Newcastle upon Tyne NE2 1QU	TEL: 0191 209 4444 FAX: 0191 209 4455	Supplier Inspector Maintainer
<b>Digital Post Solutions</b>	Apex Business Centre Unit 15 1st Floor Boscombe Road Dunstable Bedfordshire LU5 4SB	TEL: 0870 7300138 FAX: 0870 7300139	Supplier Inspector Maintainer
<b>European Postal Systems Ltd</b>	Unit D3 Lomer Farm Industrial Estate Wrotham Road Meopham, Kent DA13 0AN	TEL: 01474 815 850 FAX: 01474 815 860	Supplier Inspector Maintainer
<b>FPIMS Southern Ltd</b>	Unit 4 Saturn House Calleva Park Aldermaston Berkshire RG7 8HA	TEL: 0118 982 0988 FAX: 0118 982 0924	Supplier Inspector Maintainer
<b>Frama UK LTD (Nationwide coverage)</b>	15 Limes Court High Street Hoddesdon EN11 8EP	TEL: 01992 451 125	Manufacturer Supplier Inspector Maintainer
<b>Francotyp Postalia Ltd (Nationwide coverage)</b>	Lakeside House 74 Questor Powdermill Lane Dartford DA1 1EF	TEL: 0500 223 563	Manufacturer Supplier Inspector Maintainer



<b>Company</b>	<b>Address</b>	<b>Contact details</b>	<b>Services</b>
<b>Franking Machine Company</b>	130 St Mary's Road Liverpool L19 2JG	TEL: 0151 494 2525	Supplier Inspector Maintainer
<b>Kane Mailing Systems Ltd</b>	Glamorgan House Ystrad Mynach Hengoed CF82 7AN	TEL: 01443 813 588 FAX: 01443 813 587	Supplier Inspector Maintainer
<b>Mailcoms Limited</b>	1st Floor 6 Mill Street Cannock Staffordshire WS11 0DL	TEL: 08450 530 930 FAX: 08450 539 931	Supplier Inspector Maintainer
<b>Mailing Systems (Europe) Ltd</b>	Unit 1 Salisbury Road Milton Weston-Super-Mare N Somerset BS22 8EW	TEL: 01934 645666 FAX: 01934 645516	Supplier Inspector Maintainer
<b>Nationwide Franking Sense Ltd</b>	Nationwide House Mossbank Way Bolton BL1 8NP	TEL: 01204 303 015	Supplier Inspector Maintainer
<b>NCS Group Ltd</b>	65 Rodney Street Glasgow G4 9SQ	TEL: 0141 353 0000 FAX: 0141 353 0011	Supplier Inspector Maintainer
<b>Neopost Ltd (Nationwide coverage)</b>	South Street Romford RM1 2AR	TEL: 0800 515 297	Manufacturer Supplier Inspector Maintainer
<b>North Time and Data Ltd</b>	Enterprise Crescent Ballinderry Road Industrial Estate Lisburn BT28 2PB	TEL: 028 9260 4000	Supplier Inspector Maintainer
<b>Northern Services</b>	10 Albion Way Kelvin Industrial Estate EAST KILBRIDE G75 0YN	TEL: 01355 241 333	Supplier Inspector Maintainer
<b>NSL Mailing</b>	Cedar House Vine Lane Uxbridge UB10 0NF	TEL: 0800 276 1071 FAX: 0870 240 4118	Supplier Inspector Maintainer

<b>Company</b>	<b>Address</b>	<b>Contact details</b>	<b>Services</b>
<b>Pitney Bowes Ltd (Nationwide coverage)</b>	Elizabeth Way The Pinnacle Harlow CM19 5BD	TEL: 08444 992 992	Manufacturer Supplier Inspector Maintainer
<b>SMarTech UK plc</b>	Epworth House 25 City Road London EC1Y 1AA	TEL: 020 7689 5678 FAX: 020 7689 5679	Supplier Inspector Maintainer
<b>Totalpost Services Plc</b>	1 Skelgillside Alston Cumbria CA9 3TR	TEL: 01434 381182 FAX: 01434 382035	Supplier Inspector Maintainer
<b>Twofold Ltd</b>	77 Milford Road Reading RG1 8LG	TEL: 0118 951 9800	Supplier Inspector Maintainer
<b>Westmore Business Systems Ltd</b>	2 Arrow Court Adams Way Springfield Business Park Alcester Warwickshire B49 6PU	TEL: 0845 230 6500 FAX: 0845 230 6511	Supplier Inspector Maintainer

# ADDRESSING

## Managing Address Data

There are many benefits to maintaining your customer database with a high level of address quality, including:

- improved perception of your company and your mailings by the recipient, which may lead to increased response rates
- enhanced ability to target your mailings using demographic profiling tools
- reduced production and postage costs through the elimination of duplicate records and undeliverable items.

It's important to remember that cleaning your address data should not be a one-off activity, but an ongoing process. You need to take into account changes to Postcodes and other address information over time and ensure that new records added to your database are accurate.

Capturing customer contact data is the first step in the customer journey for many businesses. Errors at this point have a significant impact further down the line. So, to uphold customer data quality from the start, it's really important for businesses to ensure they're doing everything they can to capture accurate and up-to-date address data in order to deliver a great customer experience.

AddressNow Capture from Royal Mail is an easy-to-use, pay-per-lookup, cloud-based service which provides you and your customers with a fast, simple and accurate way to lookup, validate and capture address data online in real-time. Visit our website at <https://addressnow.royalmail.com> to find out more and to register for a FREE trial.

For general help with improving contact and address databases please contact [datasales@royalmail.com](mailto:datasales@royalmail.com) and we can recommend an approach tailored to your needs.

The best way to maintain the accuracy of your addresses is to link your customer database to the Postcode Address File (PAF®) by using one of the large number of products and services based on PAF® which are available.

PAF® contains over 28 million UK addresses, including around 1.4 million business addresses and 1.8 million Postcodes, which we constantly update to maintain its accuracy.

Managing Address Data products and services (derived from PAF®) are available in a variety of formats so you can choose the one most suitable to your business needs:

- as integrated solutions from our Data Solution Providers (independent licensed companies who use PAF® to develop and sell a range of address management products and tools)
- as raw data, which you can process to suit your IT applications
- on a CD-ROM with search and sort options

## Returns Management Service

### What is the Returns Management Service?

Royal Mail is able to provide an interception, salvage & storage service for most organisations. This can include passing on or destroying the returns & providing relevant Management Information reports. Through this Royal Mail service, it is also possible to collate, pre-sort & return undeliverable mail to organisations in order to facilitate specific business processes & individual business unit needs.

### What happens?

- The Royal Mail Returned Mail service captures the relevant name & address data often without the need to open the envelope.
- Details of return items can be available within 48 hours of item receipt – enabling the organisation to take appropriate action quickly & efficiently.
- Data Capture rules can be set by campaign, mail type, etc.
- Data can be provided in any standard format by secure transfer.
- Manual Capture or 2D barcode scanning to extract data.

### How does it work?

- The Returns Management Service uses unique DN55 postcodes on the back of mail pieces to return the items to the Doncaster Mail Centre.
- The Doncaster Mail Centre then segregate, sort and make ready for capture, return or disposal.
- The items are then sent to a third party provider that performs the data capture process and returns a data file to the team in Doncaster.
- Once data has been captured mail items can be disposed of securely or re-cycled.
- High value items from the mail packs such as catalogues etc can be repatriated for re-use.
- The data file is then processed as customer requirements and is securely returned to them on a regular basis.

### How can this service help you?

Captured data is used to amend and update existing data files. This data source allows you to:

- Remove gone away customers from the file using the data as a suppression product.
- Re assign budget that would have been lost, to data purchasing; replacing existing expired contacts with new ones and driving ROI.
- Identify potential lost clients and reconnect with them using data enhancement.

# **The National Change of Address<sup>®</sup> Update (NCOA<sup>®</sup> Update) and The National Change of Address<sup>®</sup> Suppress (NCOA<sup>®</sup> Suppress)**

## **Royal Mail NCOA<sup>®</sup> Update**

This was designed to help you to reconnect with your customers by updating their address when they move home. By maintaining an update record of your customers address you could increase the response rate of campaigns and drive Return on Investment. The NCOA<sup>®</sup> Update product helps you to reduce wasted marketing budget and environmental impact by avoiding mailing gone-aways.

## **Royal Mail NCOA<sup>®</sup> Suppress**

This enables you to remove gone away data from your prospect or customer mailings and database. It will help you make Direct Marketing more cost effective by targeting customers more effectively, enhancing your brand's image and increasing the response rates of your campaigns.

## **Further details about these products**

The information is sourced exclusively from Redirection application forms completed by consumers who are in the process of moving home. Each year Royal Mail helps over 1.2 million people moving home redirect their mail and Royal Mail is the only company who can provide you with this unique data set. Both products are available as weekly or daily additional update feeds and are in Fixed Width or Delimited file formats.

## **Royal Mail NCOA<sup>®</sup> Update highlights**

Royal Mail NCOA<sup>®</sup> Update is a forwarding address tool that allows you to update customer records with their new address;

NCOA<sup>®</sup> Update will be provided for appending forwarding addresses only.

Standard licence fees and royalties remain unchanged;

Improved data quality: all data will be PAF cleansed; linked moves will be chained;

Email and telephone data for updating existing records will be provided in the near future.

## **NCOA<sup>®</sup> Suppress highlights**

Royal Mail NCOA<sup>®</sup> Suppress is a suppression product that will allow you to remove gone-aways from your customer's database. The NCOA<sup>®</sup> Suppress product contains the full file of redirections data;

NCOA<sup>®</sup> Suppress will replace the existing USS file, but will exclusively contain Redirection sourced data to maximise quality and confidence. All third party contributed data will be removed;

Suppression and permanent flags available;

Standard licence fee and royalty charges remain unchanged;

Improved data quality: all data will be PAF cleansed; linked moves will be chained;

Database extended to mirror the same time period as the NCOA<sup>®</sup> Update file ie 1994 – current date (approx 35 million records).

## Where to go for more information on address management and data products

### Royal Mail

#### For more information or to order Managing Address Data products:

- call us on 08456 066 854, select option 2
- visit the Royal Mail website at [www.royalmail.com/amu](http://www.royalmail.com/amu)
- order products via the Royal Mail website shop at [www.royalmail.com/shop](http://www.royalmail.com/shop)

#### For more information on data products:

- visit the Royal Mail website at [www.royalmail.com/data](http://www.royalmail.com/data)

#### For more information on Returns Management,

#### Royal Mail NCOA<sup>®</sup> Update,

#### Royal Mail NCOA<sup>®</sup> Suppress

- Call the Data Services Helpdesk 08456 000 098 lines are open 08.00 - 5.30 Monday to Friday
- Visit the Royal Mail website at [Royal Mail Returns Management](#)
- email us at [datasales@royalmail.com](mailto:datasales@royalmail.com)

### Direct Marketing Association (UK)

Contact the DMA for free lists of computer bureaux, database consultants and computer software suppliers. As DMA members, all companies are subject to a strict approval process to ensure they meet quality standards and best practice. Members must abide by the DMA Code of Practice, which is monitored and administered by the independent authority of the DMA.

Direct Marketing Association (UK)

DMA House

70 Margaret Street

LONDON

W1W 8SS

Tel: 020 7291 3300

Email: [dma@dma.org.uk](mailto:dma@dma.org.uk) Web: [www.dma.org.uk](http://www.dma.org.uk)

## The elements of an address – Inland mail

- You must include one premise element, one thoroughfare element, one locality element and the postcode as a minimum.
- The post town should be included
- Other elements may be included.
- If there is no thoroughfare element contained in PAF® this need not be included.

<b>(optional)</b>	<b>Mailer Defined Information (MDI)* e.g. ZW4367</b>
	<b>D Faydherbe Operations Director</b>
<b>Organisation</b>	<b>Royal Mail</b>
<b>Sub-building</b>	<b>South Wing</b>
<b>Building name</b>	<b>Bell House</b>
<b>Building number</b>	<b>B 25 Bell Complex</b>
<b>Dependent thoroughfare</b>	<b>The Mews</b>
<b>Thoroughfare</b>	<b>300 Western Road</b>
<b>Double dependent locality</b>	<b>Otterley</b>
<b>Dependent locality</b>	<b>Hedge End</b>
<b>Post Town</b>	<b>OXFORD</b>
<b>Postcode</b>	<b>OX4 5ZZ</b>

\*see Address structure and layout for details on Mailer Defined Information

- Each address element must be on a separate line of the address with the postcode included as the last line of the address. The only exception to this is outlined in section three, Locality elements.
- The county, although not required, may be included as the penultimate line of the address
- The phrases “England”, “Great Britain” or “United Kingdom” must not be used for addresses to the UK and posted within the UK.
- Each line of the address must be left justified

The simplest way to ensure an address is correct is to check that all the elements in the appropriate PAF® record is present.

To fully describe these requirements, each element is defined as follows,

## 1 Premise elements

You must include at least one of these four elements, so that a single delivery point is defined. You don't have to include all the premise elements, even if they are included in PAF®.

<b>(optional)</b>	<b>MailerDefined Information e.g. ZW4367</b>
	<b>D Faydherbe Operations Director</b>
<b>Organisation</b>	<b>Royal Mail</b>
<b>Sub-building</b>	<b>South Wing</b>
<b>Building name</b>	<b>Bell House</b>
<b>Building number</b>	<b>B 25 Bell Complex</b>

## 2 Thoroughfare elements

PAF® will give one of three possible combinations:

- No thoroughfare: no need to include anything in this part of the address.
- A thoroughfare but not a dependent thoroughfare: include the thoroughfare.
- Both a dependent thoroughfare and a thoroughfare: include the former. If space allows you can also include the thoroughfare, though it's not compulsory.

<b>Dependent thoroughfare</b>	<b>The Mews</b>
<b>Thoroughfare</b>	<b>300 Western Road</b>

## 3 Locality elements

You must include at least one locality element. You don't have to include them all, even if they are included in PAF®. The Post Town should have the first character(s) in capitals for example: Coventry, Milton Keynes, Ross On Wye, on a single line.

The Post Town maybe followed by a county on the penultimate line of the address, provided that the space between Post Town and county is no more than two character spaces and that the postcode is on the last line of the address.

The county and the postcode may be on the same line provided there are one or two character spaces between the two elements.

The Post Town and postcode can be on the same line, provided that the Post Town precedes the postcode and the space between the two elements is one or two character spaces.

<b>Double dependent locality</b>	<b>Otterley</b>
<b>Dependent locality</b>	<b>Hedge End</b>



## 4 Postcode

The address must contain the full and accurate postcode. The postcode must be able to generate an address from PAF® which can be matched to the minimum requirements above (at least one premise element, one thoroughfare element and one locality element).

The postcode must always appear in capital letters on the last line of the address.

Please put one or two character spaces between the two parts of the postcode. Typically, the first part (i.e. OX4) is the outward code and this identifies a post town or a district within a post town, the second (i.e. 5ZZ) is the inward code which represents the street information.

<b>Post Town</b>	<b>OXFORD</b>
<b>Postcode</b>	<b>OX4 5ZZ</b>

## Punctuation

- Punctuation is permitted for postings which are either Barcoded or which do not receive any other machineable discounts e.g., Business Mail's non-machine-readable unsorted option.
- Please do not underline any part of the address or postcode.
- In Optical Character Recognition (OCR) postings e.g. Advertising Mail Unsorted, Business Mail Unsorted, Advertising Mail Low Sort or Business Mail Low Sort, punctuation and non-alpha numeric symbols can only be used where it appears in the corresponding PAF™ record. It can also be used in the recipient's name or in the Mailer Defined Information (MDI) above the address within the address block. There must be no punctuation used to separate address elements or components within an address element.
- Alternatively, you may remove all punctuation from the address, even if it is contained in the corresponding PAF™ record
- For full details on allowable punctuation within a PAF record please see PAF™ Digest, available from [www.royalmail.com](http://www.royalmail.com) or a member of your account team.
- Punctuation and graphical symbols may be used within any 'Mailer Defined Information' and addressee elements.

## British Forces Post Office (BFPO) Addresses

A full list of BFPO addresses is available here [HM Forces Mail](#).

Address layout is as follows & please note that the Town & Country must not be included:

**Service No Rank Name**

**Unit/Regt**

**Operation Name**

**BPFO No**

Please go to [www.royalmail.com](http://www.royalmail.com) and HM Forces Mail for full details, and any restrictions - [Royal Mail HM Forces Mail](#) .

# ADDRESS STRUCTURE AND LAYOUT

An address may consist of three elements, all of which are classed as the 'Address Block'.

1. Mailer Defined information (MDI) – reference information printed as part of the Address Block
2. Recipient details
3. Geographical address and postcode



## Address requirements

	Requirements
<b>No of addresses</b>	There must only be one Delivery Address Block on the mail piece
<b>Mailer Defined Information format (MDI)</b>	<ul style="list-style-type: none"> <li>• Must be in a single line above the address</li> <li>• The first character of the MDI must be left justified and aligned to the address below it</li> <li>• Any separation between elements of the MDI should not exceed one space</li> <li>• The content may be of different font and size to the other Address Block elements</li> <li>• The font and size may vary within the Mailer Defined Information (MDI)</li> <li>• The line spacing must be consistent with the Delivery Address</li> <li>• The length of the MDI must not exceed 64 characters</li> <li>• When included as part of the address block, it may tap out totally or partially above and to the right</li> </ul>
<b>Punctuation &amp; graphic symbols</b>	<ul style="list-style-type: none"> <li>• Please refer to 'Punctuation' under 'Addressing'</li> </ul>
<b>Fonts</b>	<ul style="list-style-type: none"> <li>• The font size for the Delivery Address must be the same or larger than the Return Address Block</li> <li>• Italic fonts must not be used</li> <li>• Bold fonts must not be used</li> <li>• Recommended fonts as follows and are point size 10-12.</li> </ul>
<b>Fonts continued</b>	<ul style="list-style-type: none"> <li>• Please note that not all the following fonts are permitted for Response Services or Business Mail – Advanced, please refer to appropriate user guide of the product for further details.</li> </ul>

Requirements																									
<b>Address Block Text formatting</b>	<p><b>Non-Proportionally Spaced preferred fonts (7)</b>  Courier  Courier New  Letter Gothic  Lucida Console  Lucida Sans Typewriter  OCR B  Word Gothic</p> <p><b>Acceptable Proportionally Spaced fonts (23)</b></p> <table style="width: 100%; border: none;"> <tr> <td>Arial</td> <td>Latha</td> </tr> <tr> <td>Avant Garde</td> <td>Lucida Sans</td> </tr> <tr> <td>Calibri</td> <td>Mangal</td> </tr> <tr> <td>Estrangelo Edessa</td> <td>News Gothic MT</td> </tr> <tr> <td>Eurostile</td> <td>Univrs</td> </tr> <tr> <td>Frankfurt Gothic</td> <td>Optima</td> </tr> <tr> <td>Franklin Gothic (Book)</td> <td>Raavi</td> </tr> <tr> <td>Gautami</td> <td>Shruti</td> </tr> <tr> <td>Geneva</td> <td>Trebuchet MS</td> </tr> <tr> <td>Gill Sans</td> <td>Tunga</td> </tr> <tr> <td>Helvetica</td> <td>Univrs</td> </tr> <tr> <td></td> <td>Verdana</td> </tr> </table> <p>* Note that all the fonts above are in the correct type</p>	Arial	Latha	Avant Garde	Lucida Sans	Calibri	Mangal	Estrangelo Edessa	News Gothic MT	Eurostile	Univrs	Frankfurt Gothic	Optima	Franklin Gothic (Book)	Raavi	Gautami	Shruti	Geneva	Trebuchet MS	Gill Sans	Tunga	Helvetica	Univrs		Verdana
	Arial	Latha																							
	Avant Garde	Lucida Sans																							
	Calibri	Mangal																							
	Estrangelo Edessa	News Gothic MT																							
	Eurostile	Univrs																							
	Frankfurt Gothic	Optima																							
	Franklin Gothic (Book)	Raavi																							
	Gautami	Shruti																							
	Geneva	Trebuchet MS																							
Gill Sans	Tunga																								
Helvetica	Univrs																								
	Verdana																								
<ul style="list-style-type: none"> <li>• The address must be provided as a 'block' of text.</li> <li>• The content of one address line must not be wrapped on to a second line of text i.e. London Road must be printed on the same line and not be spread over 2 lines.</li> <li>• Characters of the same font and point size must be used for each line of the address</li> <li>• Character pitch must be 10-12 characters per 25.4mm with clear vertical gaps of at least 0.25mm between the extremities of adjacent characters.</li> <li>• Spacing between words must be &lt; 5mm</li> <li>• Maximum characters per line of the Address Block is 64 characters (including spaces)</li> <li>• Spacing between lines must be uniform: Minimum - 1mm, Maximum - 4mm</li> <li>• There must be no "blank" lines in the address</li> <li>• All elements of the Address Block (including the Mailer Defined Information) must be left justified</li> <li>• The Address Block skew must be no more than ± 5 degrees</li> </ul>																									

## Address print requirements

	Requirements
<b>Print colour &amp; quality</b>	<ul style="list-style-type: none"><li>• Preferred colour is black. If this cannot be achieved then adequate contrast must be achieved</li><li>• Negative contrast is not allowed</li><li>• The characters must not be blurred, smudged, deformed or incomplete</li><li>• No splashing or ink splatter around characters</li></ul>
<b>Print contrast</b>	<ul style="list-style-type: none"><li>• Required Print Contrast Ratio for addresses printed on envelopes <math>\geq 50\%</math></li><li>• Required Print Contrast Ratio for addresses printed on window inserts <math>\geq 55\%</math></li><li>• Required Value: Minimum Reflective Difference <math>\geq 30\%</math></li><li>• Required Value: Minimum Background Reflectance <math>\geq 35\%</math></li><li>• Inverse printing is not allowed (address block lighter than background)</li></ul>

### Address print advice for labels

If you wish to print all your address and indicia information on a label we would recommend that, as per the advice in this guide, you follow the general principle of ensuring that

- a) the indicia is to the top right of the item
- b) the delivery address is central / to the left of the indicia
- c) the delivery address and indicia are both orientated in the same direction
- d) the return address to be above and to the left of the delivery address
- e) all other requirements e.g clear zones, layout, address structure remain as per this guide

# Examples showing the layout of information on an address label

Return Address  
Royal Mail  
185 Farringdon Road  
London  
EC1A 1AA

Delivered by



**ROYAL MAIL**

POSTAGE PAID GB  
SOUTHAMPTON 2500

Mr AB Sample  
Sample Building  
Sample Street  
Sample Town  
AB1 2DE

Return Address  
Royal Mail  
185 Farringdon Road  
London  
EC1A 1AA

Delivered by



**ROYAL MAIL**

POSTAGE PAID GB  
SOUTHAMPTON 2500

Mr AB Sample  
Sample Building  
Sample Street  
Sample Town  
AB1 2DE

Return Address  
Royal Mail  
185 Farringdon Road  
London  
EC1A 1AA

Delivered by



**ROYAL MAIL**

POSTAGE PAID GB  
SOUTHAMPTON 2500

Mr AB Sample  
Sample Building  
Sample Street  
Sample Town  
AB1 2DE

## Return Address

We do recommend that a valid UK return address is applied to all mail.

When a return address is applied to the mail piece, it must comply with the following requirements:

1. The content of the return address must follow the Delivery Address structure as per the 'Addressing' chapter.
2. The first line must identify the address as a return address and must state the words 'Return Address'

An example of a return address is provided:

Return Address  
Royal Mail House  
Rowland Hill Close  
Dorcan  
Swindon  
SN3 5TQ

### Return Address formatting

	Requirements
<b>All mail</b>	<ul style="list-style-type: none"><li>• The format must follow the delivery address requirements as per the 'Addressing' chapter</li></ul>
<b>Mail other than franked mail</b>	<ul style="list-style-type: none"><li>• The font size for the return address on mail other than franked mail must be the same or smaller than the font of the delivery address</li><li>• The exception to this is for mail posted as 'Articles for the Blind'</li></ul>
<b>Franked mail specifics</b>	<ul style="list-style-type: none"><li>• Where only the return address is printed in the 'slogan block area' on Franked mail, return addresses must be printed using either the 'Lucida Console' or 'Letter Gothic' fonts in 10-14pt.</li><li>• Where both a return address and slogan are required in the 'slogan block area' on Franked mail, the following rules must be applied:<ol style="list-style-type: none"><li>a) return address on must be printed using either the 'Lucida Console' or 'Letter Gothic' fonts of 6-14pt (8pt recommended)</li><li>b) when the Return Address is printed in the slogan box with the BMA Licence it must be 12pt</li><li>c) Slogans where the company name contains the words 'Return', 'Address' and 'Undelivered' should be avoided.</li></ol></li></ul>

## Return Address location

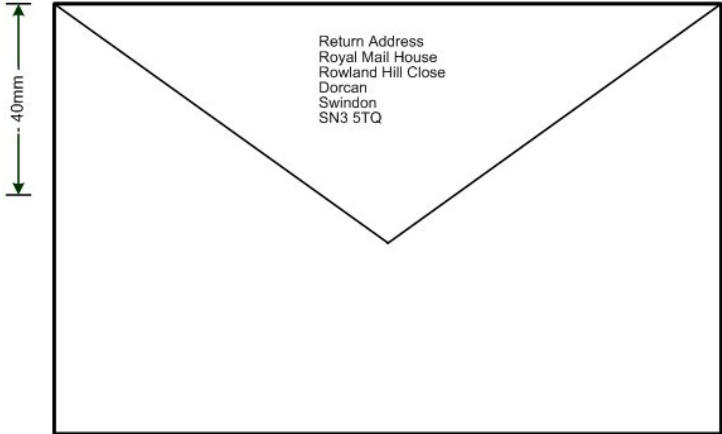
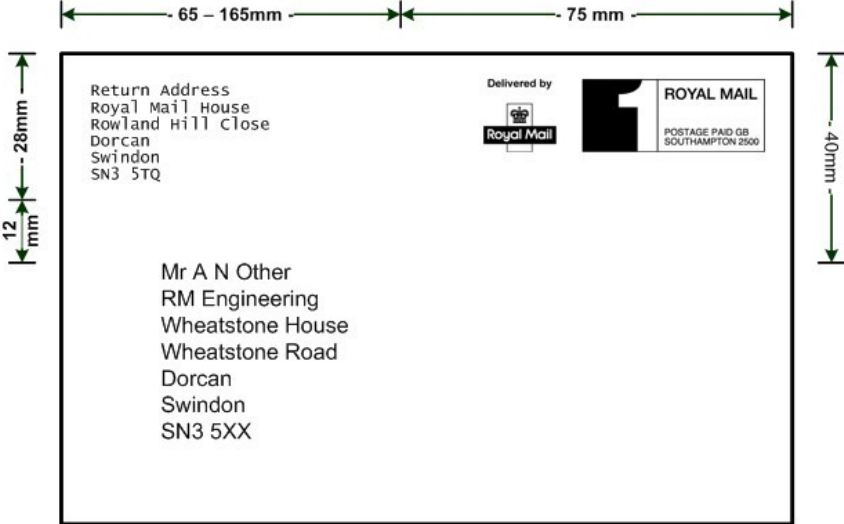
	Requirements
<b>Location</b>	<ul style="list-style-type: none"> <li>Ideally should be centrally placed on the reverse of the mail piece</li> </ul> 
<b>Position if on reverse</b> <b>Position if on the front - non franked mail</b>	<ul style="list-style-type: none"> <li>In an area within 40mm zone from the top of the mail piece</li> <li>In the top left corner</li> <li>Less than 75mm from the right edge</li> <li>Extend to no lower than 28mm from the top edge of the letter</li> <li>No closer than 12mm to the Delivery Address</li> </ul> 
<b>Position if on the front - franked mail</b>	<ul style="list-style-type: none"> <li>To the left of the Franked indicia.</li> <li>A clear zone of 5mm-20mm must be provided to the left and to the right of the return address</li> </ul>

## Window Envelopes

If your letter has a window, please see the following requirements.

	Requirements
<b>Aperture</b>	<ul style="list-style-type: none"> <li>• Not to be an open space</li> <li>• There must be a transparent film (window) placed across the aperture</li> </ul>
<b>No of windows on the front</b>	<ul style="list-style-type: none"> <li>• Maximum of two windows on the front</li> <li>• If there is a window on the reverse, the maximum permitted on the front is one</li> </ul>
<b>No of windows on the reverse</b>	<ul style="list-style-type: none"> <li>• Maximum number of windows permitted on the reverse is one.</li> <li>• Please refer to the product specific user guides to see if this is permitted for your product and for the full design requirements</li> </ul>
<b>Size</b>	<ul style="list-style-type: none"> <li>• The sum of the area of windows applied to a single side must not be more than 50% of the surface area for that side</li> </ul>
<b>Window shape</b>	<ul style="list-style-type: none"> <li>• Must be rectangular if on the front.</li> <li>• The corner of the aperture must be rounded to prevent damage to the item</li> <li>• Must be circular if on the reverse</li> </ul>
<b>Position</b>	<ul style="list-style-type: none"> <li>• Must not interfere with the tag codemark and route codemark clear zones. Please refer to 'Clear Zones – Design Requirements'</li> <li>• Must not interfere with the indicia area</li> <li>• Must be more than or equal to 18mm from the bottom edge of the mail piece</li> <li>• Must be more than or equal to 15mm from the right, left and top of the mail piece</li> </ul>
<b>Gloss</b>	<ul style="list-style-type: none"> <li>• The gloss value must be <math>\leq 150</math> (American standards of testing and materials (ASTM) 2457 Measured at 60 degrees).</li> </ul>
<b>Haze</b>	<ul style="list-style-type: none"> <li>• The haze value must be <math>\leq 75\%</math> (ASTM D1003-00 Procedure A (Hazemeter))</li> </ul>
<b>Strength</b>	<ul style="list-style-type: none"> <li>• The window must be robust enough not to become deformed. i.e. not creased or crumpled</li> </ul>



# ADDRESS CLEARZONES & LOCATION

## Delivery Address Block Clear zone

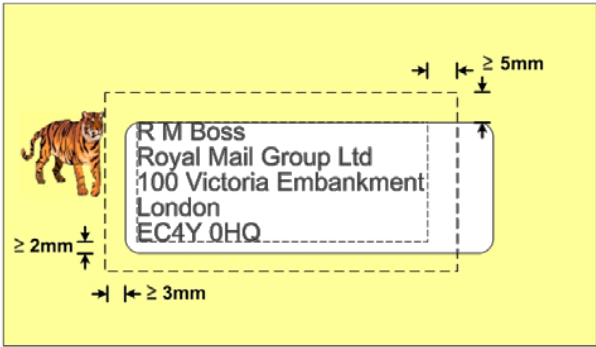
Requirements	
<b>Minimum required around the entire Address Block</b>	<ul style="list-style-type: none"> <li>More than or equal to 5mm</li> </ul>  <p style="text-align: center;">             CT 294              R M Boss              Royal Mail Group Ltd              100 Victoria Embankment              London              EC4Y 0HQ         </p>
<b>Window envelopes</b>	<ul style="list-style-type: none"> <li>Total clearance around the address block remains unchanged at <math>\geq 5\text{mm}</math>. This may consist of clear zones both within the window and on the envelope</li> <li>The gap within the window must be <math>\geq 2\text{mm}</math> to the left, right, and bottom of the address.</li> <li>No clear zone is required within the window above the address block, but the address block must always be visible. The remaining clear zone requirements are met through the provision of clear zones on the envelope. i.e. a clear zone of <math>\geq 3\text{mm}</math> to the left, right, and bottom of the Address Block; and a <math>\geq 5\text{mm}</math> clear zone on the envelope above the address.</li> </ul>  <p style="text-align: center;">             R M Boss              Royal Mail Group Ltd              100 Victoria Embankment              London              EC4Y 0HQ         </p>
<b>Text, graphics and patterns</b>	<ul style="list-style-type: none"> <li>No other text, patterning, or graphics may be printed within this clear zone. Mailer Defined Information (MDI) may be included if it part of the address block.</li> </ul>
<b>Other text/information</b>	<ul style="list-style-type: none"> <li>No other text/information that could be construed as a delivery address may be included on the front of the mail piece. This includes any areas of an insert which may appear in the window of the mail item arising from insert movement</li> </ul>

## Delivery Address Block location

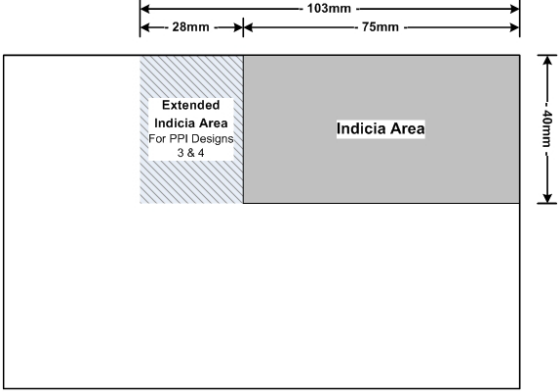
	Requirements
<b>Orientation</b>	<ul style="list-style-type: none"> <li>Must always be in landscape orientation</li> <li>Unless this is a Mailmark Barcoded letter i.e. Advertising Mail, Business Mail Unsorted or Advertising Mail, Business Mail Low Sort in</li> </ul>
<b>Location to indicia area</b>	<ul style="list-style-type: none"> <li>The Delivery Address Block must not encroach into the Indicia area. See below - the Indicia area is located in the top right corner of the mail piece and is an area 40mm high from the top edge of the mail piece and 75mm long (from the right edge of the letter)</li> </ul>  <p>The diagram shows a rectangular area in the top right corner of a mail piece. It is divided into two parts: a shaded 'Extended Indicia Area' on the left, which is 28mm wide and 40mm high, and a grey 'Indicia Area' on the right, which is 75mm wide and 40mm high. The total width of this combined area is 103mm. The height of both areas is 40mm, measured from the top edge of the mail piece.</p>
<b>Location to Clear Zones (see Clear Zones)</b>	<p>The Delivery Address Block must not encroach on the clear zones for 'Tag'<sup>1</sup> and 'Route'<sup>2</sup> codes of the mail piece</p> <ul style="list-style-type: none"> <li>'Tag' codemark - Positioned 60mm up from the bottom right corner of the mail piece, and covering an area 10mm high, and 100mm long (from the right edge of the letter)</li> <li>'Route' codemark - Positioned in the bottom right corner of the mail piece and covering an area 18mm high (from the bottom edge of the letter), and 130mm long (from the right edge of the letter)</li> </ul> <p><sup>1</sup> item reference code as applied by our machines - see 'Clear Zones'</p> <p><sup>2</sup></p>
<b>Location to border of the item</b>	<ul style="list-style-type: none"> <li>A clear border (of window material &amp; address block information) is also required around the perimeter of the item.</li> <li>The size of the border is 15mm for the top, left, &amp; right borders and 18mm for the bottom border.</li> </ul>
<b>Location to bottom edge of the item</b>	<ul style="list-style-type: none"> <li>For landscape mail, no part of the Delivery Address Block must be located more than 125mm above the bottom reference edge of the letter</li> </ul>
<b>Location of last line of the address block</b>	<ul style="list-style-type: none"> <li>The last line of the geographic address must always be &gt; 50mm from the top reference edge of the letter.</li> </ul>

# CLEAR ZONES - DESIGN REQUIREMENTS

## Letter format

The following information provides further detail on the clear zones required to allow us to be able to process your letters efficiently and quickly through our operational pipeline.

There are two areas on letter format items which we request are kept clear of print, graphics and window material so that we can apply both codes to each letter.

These codes are:

- The 'tag' codemark - this is a reference applied to that letter in the event we are not able to sort the item first time through the machine.
- The 'route' codemark - this is the reference obtained through reading the address information which enables the machine to sort the letter to the correct selection on the machine.

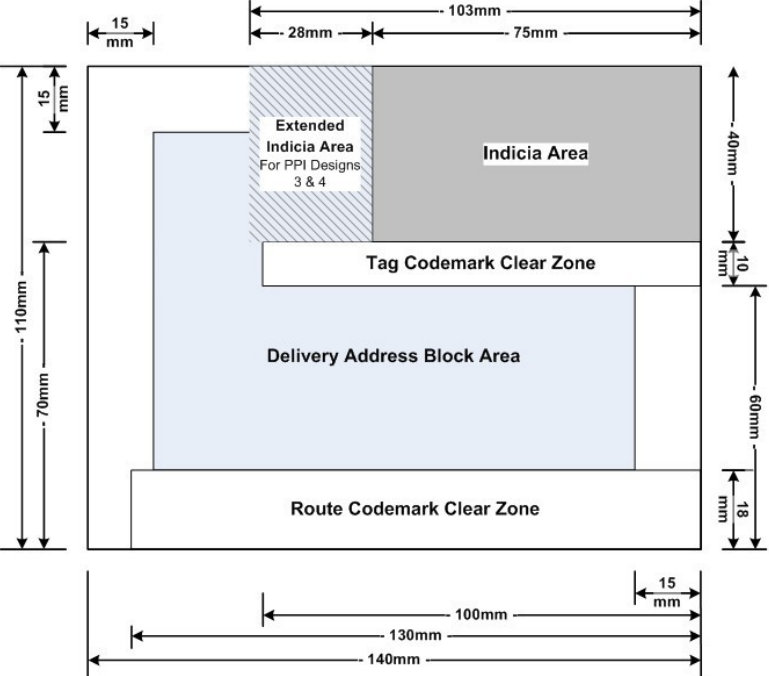
	Requirements
<b>'Tag' code area</b>	<ul style="list-style-type: none"> <li>• Tag codemark - Positioned 60mm up from the bottom right corner of the mail piece, and covering an area 10mm high, and 100mm long (from the right edge of the letter)</li> </ul>
<b>'Route' code area</b>	<ul style="list-style-type: none"> <li>• Route codemark - Positioned in the bottom right corner of the mail piece and covering an area 18mm high (from the bottom edge of the letter), and 130mm long (from the right edge of the letter)</li> </ul>
<b>Example of 'Tag' and 'Route' code areas</b>	 <p>The diagram illustrates the layout of a letter with various zones and dimensions. Key dimensions include:</p> <ul style="list-style-type: none"> <li>Top margin: 15 mm</li> <li>Right margin: 15 mm</li> <li>Indicia Area: 103 mm wide, 40 mm high</li> <li>Extended Indicia Area: 28 mm wide, 15 mm high</li> <li>Tag Codemark Clear Zone: 100 mm wide, 10 mm high</li> <li>Delivery Address Block Area: 70 mm high</li> <li>Route Codemark Clear Zone: 130 mm wide, 18 mm high</li> <li>Bottom margin: 18 mm</li> <li>Overall width: 140 mm</li> <li>Overall height: 110 mm</li> </ul>

	Requirements
<b>'Picture frame'</b>	<ul style="list-style-type: none"> <li>• There is a picture frame of 15mm on the right, left and top of the envelope and 18mm along the bottom where there is to be no window material, or address block information in this area</li> </ul>
<b>PPI area</b>	<ul style="list-style-type: none"> <li>• Can go into this area but must not go into the indicia's clear area which varies as follows, <ul style="list-style-type: none"> <li>• Responses services is variable, please refer to Response Service specification</li> <li>• Franking impressions require 2mm</li> <li>• PPIs require 2mm</li> </ul> </li> </ul> <div data-bbox="668 663 1370 1149" data-label="Diagram"> <p>The diagram illustrates the layout of the PPI area and the indicia area. The PPI area is a rectangle with a width of 28mm and a height of 40mm. The indicia area is a rectangle with a width of 75mm and a height of 40mm. The total width of the combined areas is 103mm. The PPI area is labeled 'Extended Indicia Area For PPI Designs 3 &amp; 4' and the indicia area is labeled 'Indicia Area'.</p> </div>

## Background colours permitted in the 'Tag' and 'Route' code areas

The following Pantone colours are the darkest acceptable for use as background colours in the codemark areas of the mail piece. e.g. Red, Green, and Black substrates are not acceptable.

Page No / U	Colour Code	Page No / U	Colour Code	Page No / U	Colour Code	Page No / U	Colour Code
2	104U	25.3	2583U	45.5	3985U	66.5	5425U
3	111U	26	265U	46	403U	67	550U
3	112U	26.5	2655U	47	409U	67.7	5507U
4	118U	27	272U	49	423U	68	557U
5	125U	27.5	2715U	52	442U	68.5	5565U
5.5	1255U	28	278U	52.1	WG5U	69	564U
6	132U	30	291U	52.1	WG6U	69.5	5635U
7	139U	30.5	2905U	52.1	WG7U	70	571U
7.5	1395U	31	297U	52.3	CG7U	71	577U
8	146U	33.5	3105U	52.4	CG8U	71.3	5773U
9.5	1535U	34	318U	53	451U	72	583U
10.5	1605U	35.2	3242U	54	456U	72.5	5835U
11.5	1675U	35.5	3245U	54	457U	76	623U
13	180U	35.8	3248U	55	463U	77	630U
13.5	1805U	37	337U	55	464U	78	637U
14	187U	37.5	3375U	55.5	4645U	79	644U
15	194U	38	345U	56.5	4715U	80	651U
15.5	1955U	39	352U	58	484U	81	658U
16	202U	40	359U	60	500U	82	667U
17	208U	41	367U	60.5	4995U	84	682U
18	215U	42	374U	63	521U	86	696U
19	221U	44	390U	64.5	5285U	87	704U
23	249U	45	397U	65	535U	90	724U
25.2	2602U	45	398U	66	543U	91	730U

**Please note:** Colours shown are an approximation of uncoated shade permitted.

## GENERAL ADVICE

### General advice for print quality & finishing

Digital printing processes apply a pigmented layer that adheres to the surface of the paper. The layer does not soak into the paper and is softer than standard inks.

Consequently, when used for mail, the pigment may rub off, transfer to adjacent surfaces (inserts and the envelope), crack, and become marked both during the manual and automated handling process.

The application of an ultra violet (UV) cured varnish has been found to reduce the wear to digitally printed mail items. This provides a protective coating over the pigment. It should only be applied to the non-address side of the Letter as the characteristics the varnish may make the mail unmachineable if applied to both sides\*.

(\*They may have 'window-like characteristics' that reduce mechanical handling capability, increase static cling, and compromise codemark printing)

The pressure exerted on the Letter during automated processing may cause colour offset on digitally printed items. Therefore, it is recommended that there should be no off-set of print or colour transfer when the item is exposed to a pressure of 3.43kPa (35g per cm<sup>2</sup>). This equates to a weight of 8.5kg spread over the surface of a DL envelope, and 13.5kg for C5 envelopes.

## Where to go for help or more information

To find out more about any Royal Mail product or service please visit [Royal Mail Ltd](#). If you wish to know more about our machineable letter products, including being able to compare products by using a handy pricing calculator please visit;

<http://www.royalmailtechnical.com/products.cfm>

Alternatively, please call your Royal Mail Sales Centre on 08457 950 950 (local rate) or if you are deaf or hard of hearing we offer a textphone service on 08456 000 606.

## Useful web links

Service or Contact	Link
Address Management	<a href="#">Address Management Unit</a>
Advertising Mail Big Book	<a href="#">Advertising Mail Big Book</a>
British Forces Address (BFPO)	<a href="http://www.bfpo.mod.uk">www.bfpo.mod.uk</a>
British Forces website	<a href="#">HM Forces Mail</a>
Clear Communications	<a href="#">Clear communications</a>
Clear Prospects®	<a href="#">Clear Prospects</a>
Customer Service – Royal Mail	<a href="#">Royal Mail Customer Service</a>
Data products	<a href="#">Address Data Products</a>
Direct Marketing Association (UK) (DMA)	<a href="http://www.dma.org.uk">www.dma.org.uk</a>
Discounts & Payment	<a href="#">Discounts &amp; Payment.</a>
Franking machine information (including Manufacturers, Independents, Inspectors and Maintainers)	<a href="#">Royal Mail Franking</a>
HM Forces Mail	<a href="#">Royal Mail HM Forces Mail</a>
International Mail	<a href="#">Royal Mail International Mail</a>
Mailshots Online	<a href="#">Mailshots Online</a>
Click & Drop	<a href="#">Royal Mail Click &amp; Drop</a>
Postcode Address File® (PAF®)	<a href="#">Postcode Address File (PAF)</a>
Prepaid Stationery	<a href="#">Royal Mail Pre-Paid Stationery</a>
Printed Postage Impression producer	<a href="#">online PPI producer</a>
Printed Postage Impression Terms and Conditions	<a href="#">Terms and Conditions</a>
Printed Postage Impressions	<a href="http://www.royalmail.com/ppi">www.royalmail.com/ppi</a> <a href="http://www.royalmail.com/bilingualppi">www.royalmail.com/bilingualppi</a>

Service or Contact	Link
Response Services	<a href="#">Response Services</a>
Returns Management	<a href="#">Royal Mail Returns Management</a>
Royal Mail	<a href="#">Royal Mail Ltd</a>
Royal Mail products	<a href="http://www.royalmail.com/shop">www.royalmail.com/shop</a>
Royal Mail Technical	<a href="http://www.royalmailtechnical.com/products.cfm">http://www.royalmailtechnical.com/products.cfm</a>
Royal Mail Tracked™	<a href="#">Royal Mail Tracked</a>
Stamps	<a href="#">Royal Mail Stamps</a>
Terms and Conditions	<a href="#">Terms and Conditions</a>
User Guide for Marketing, Publishing and General Correspondence	<a href="#">Royal Mail Technical</a>